

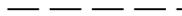









### LEGENDA

-  Bebouwingsvlak
-  Kadastrale grens
-  Optionele uitbouw woonkamer  
1.20m of 2.40m
-  Optie garage
-  Bouwnummer
-  Entree woning
-  Beschoeiing
-  Talud
-  Haag, 1.80m hoog
-  Haag, 1.00m hoog
-  Privé parkeerplaats
-  Water

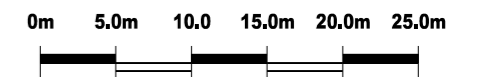

**JURIDISCHE TEKENING  
WONINGBOUWLOCATIE CORELLISTRAAT  
TE SLIEDRECHT**

**SCHAAL: 1:500**

**DATUM: 15-04-2021**

**STATUS: CONCEPT**

**TEKENINGNUMMER: W21-40183-10-PO-01**